

► Air Cooled Water Chillers

CLS 182 to 602



41 to 150 kW



HFC 407C



Technical Brochure
TM CLS-W.3GB
Date : October 2004
Supersedes : TM CLS-W.2GB/07.04

Wesper®

Specifications

General characteristics

The CLS air cooled water chillers have been designed to operate with the **HFC 407C** refrigerant.

They are complete with **two independent refrigerant circuits** fitted with a high efficiency and low vibration level Scroll compressor on each circuit.

These units are suitable for outdoor installation on the roof of a building or on the ground.

All the CLS units are completely factory tested in compliance with the internal quality system specifications and procedures, and are ready for field installation.

The "Plug and Play" concept has been introduced in each CLS unit, thanks to the use of BMS compatible microprocessor-based control system and to the **integrated hydraulic module** supplied as optional on all versions of the CLS range.

Also, thanks to the versions and options available, the CLS air cooled water chillers can fit all the demands of the market.

The CLS range is available in **5 versions**; each version is composed of **9 sizes**.

CLS STD : Standard version fitted with standard equipment intended for reliable operation. The CLS STD units cover a nominal cooling capacity range from 41 to 150 kW.

CLS LN : Low noise version having same equipment as STD version, except that it is fitted with low speed type larger size fans. The CLS LN units cover a nominal cooling capacity range from 41 to 150 kW.

CLS ELN : Extra low noise version fitted with greater heat exchange surface area condenser coils, very low speed type fans and a stepless fan speed controller. Furthermore, the ELN version is equipped with a reinforced soundproofing :

- mufflers mounted on compressor discharge lines (all sizes),
- soundproofing jacket on compressor (sizes 182 to 302),
- sound insulation on compressor compartment (sizes 352 to 602).

The CLS ELN units cover a nominal cooling capacity range from 41 to 150 kW.

CLS HPF : High pressure fan version having same equipment as STD version, except that larger size fans with 80 Pa external static pressure are fitted on this HPF version. The CLS HPF units cover a nominal cooling capacity range from 41 to 145 kW.

CLS HT : High temperature version having same equipment as STD version, except that it is fitted with fans allowing unit to operate at high ambient temperatures (up to +48 °C). The CLS HT units cover a nominal cooling capacity range from 44 to 155 kW.

Reference standards

The following applies to all the sizes and versions belonging to the CLS units :

- ✓ Performance test EN 12055
- ✓ Machine Directive CEE 89 / 392
- ✓ Low Voltage Directive CEE 73/23 (EN 60204-1)
- ✓ Electromagnetic Compatibility Directive CEE 89/336 as modified by Directive CEE 92/31 (EN 50081-1, EN 50082-2)

Cabinet and structure

The unit structure shall be of heavy gauge galvanized steel fastened with non-corrosive screws and bolts. Galvanized steel parts shall be painted with baked on enamel colored white (**RAL 9001**).

Compressors

Each unit shall be equipped with 2 Scroll hermetic compressors.

Compressors on all models shall be mounted on rubber anti-vibration pads and have direct on line starting.

The compressor motors shall be refrigerant gas cooled, with integral thermistor protection against overloads. The overload protection is automatically reset.

The motor terminal boxes shall have IP-54 weather protection.

Evaporator

Evaporators are of a brazed stainless steel plate type heat exchanger. They are insulated with a closed cell foam material and are fitted with an electric cable resistance to prevent the unit from freezing at a low temperature when the unit is off.

Design working pressure shall be 10 bar on the water side and 30 bar on the refrigerant side.

Water connections are of a 2 " Victaulic type on each evaporator. Optional inlet and outlet 2" male threaded gas type manifolds can be supplied to ensure single flow and return water connections.

Condenser coils

The condenser coils shall be seamless copper tubes, arranged in staggered rows, mechanically expanded into corrugated aluminum fins.

Condenser coil fans

The condenser fans shall be direct drive with aluminum wing contour blades. Each fan will have a painted galvanized steel protection guard.

The totally enclosed fan motors shall have IP 54 degree of protection and thermo-contact protection embedded in their windings.

Fan controls

Each unit can be equipped, as optional , with a stepless fan speed controller, operating on the basis of condensing pressure, to keep fan rpm under control in order to operate at a low ambient temperature (-18 °C).

This fan speed controller is supplied as standard on the ELN units. However, it is not available on HPF and HT units.

Refrigerant circuits

All the units are composed of two independent and separate refrigerant circuits. All the components that constitute each circuit are shown on the functional diagram (see chapter "Refrigerant flow diagram").

Integrated hydraulic module (optional)

Units can be supplied with optional integrated hydraulic module composed of water tank and 1 or 2 pumps complete with accessories.

Antifreeze heater is supplied as standard in the tank.

Units can also be supplied with pump kit only (with 1 or 2 pumps).

Specifications (continued)

Power and control panel

The control compartment shall contain an electronic circuit board and a key control panel with display of operating parameters, alarms and stops.

Thermal relays and fuses are supplied to protect compressors, fans and pumps from overloading.

Control and safety devices

Each CLS unit is fitted with the following devices :

Safety :

- ✓ Fan thermal protection.
- ✓ Compressor thermal protection.
- ✓ Water differential pressure switch.
- ✓ High pressure switch.
- ✓ Evaporator antifreeze protection.
- ✓ Low pressure switch.
- ✓ Crankcase heater.

Control :

- ✓ Evaporator water inlet temperature sensor.
- ✓ Evaporator water outlet temperature sensor.

Control

Factory-installed accessories and options

- ✓ Coils with hydrophilic coated fins.
- ✓ Coils with vinyl coated fins.
- ✓ Coils with polyurethane coated fins.
- ✓ Copper / Copper coils.
- ✓ LP & HP manometers.
- ✓ Condenser coil guards.
- ✓ Integrated hydraulic module with water tank, antifreeze resistance and 1 or 2 pumps.
- ✓ Pump kit with 1 or 2 pumps.
- ✓ Compressor overload protection kit.
- ✓ Inlet and outlet water connection manifolds.
- ✓ Phase monitor.
- ✓ Stepless fan speed controller (STD and LN versions).

Field-installed accessories

- ✓ Water filter.
- ✓ Flow switch.
- ✓ Spring anti-vibration mounts.
- ✓ Remote control kit (On/Off, Cooling).
- ✓ Modbus interface kit.
- ✓ Remote keyboard panel.
- ✓ Chiller sequencer (4 units maximum).

Controller display panel

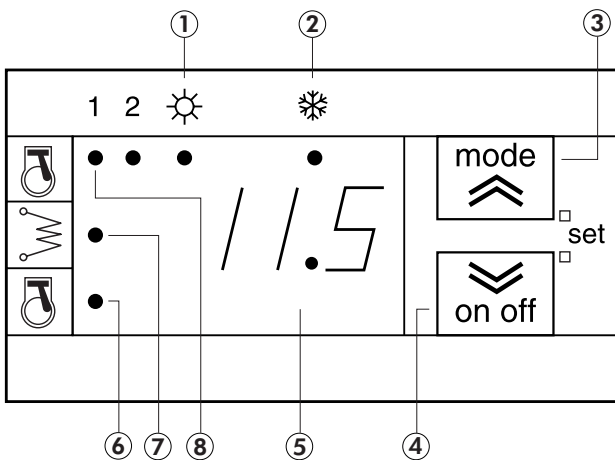

The controller provides information on status of operation, configuration and alarms through a display and LEDs on the front panel.

Display

It allows mainly to show :

- the entering water temperature of the unit in tenths of degrees Celsius with a decimal point,
- the alarm code if at least one alarm is active.

LEDs

- 1 - Heating mode display : not used
- 2 - Cooling mode display
- 3 - Operating mode selection
- 4 - Unit On/Off; Alarm restoration
- 5 - Display
- 6 - Compressor 2 ON LED (Blink : time delay in progress)

If COOLING LED is OFF, the controller is in STANDBY mode.

Remote control kit (optional)

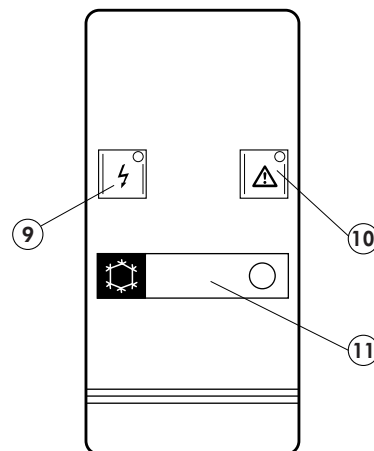

- 7 - Electric resistance ON LED
- 8 - Compressor 1 ON LED (Blink : time delay in progress)
- 9 - Voltage ON LED
- 10 - Unit activated alarm LED
- 11 - Start key and LED - Cooling

Refrigerant Flow Diagram

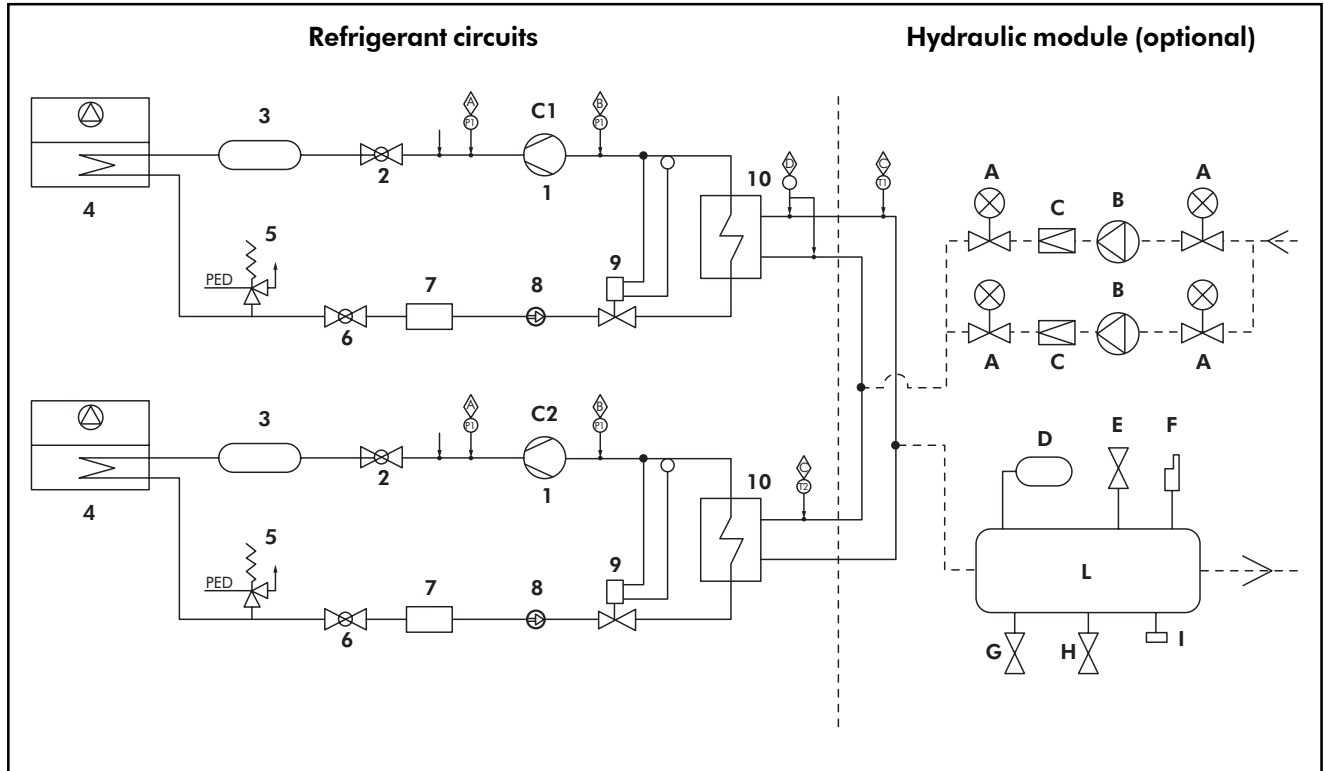

Components (refrigerant circuits) :

- 1 - Compressors C1, C2
- 2 - Discharge valve
- 3 - Muffler (for ELN version only)
- 4 - Air cooled condenser
- 5 - PED pressure relief valve
- 6 - Liquid valve
- 7 - Filter drier
- 8 - Sight glass
- 9 - Expansion valve
- 10 - Plate heat exchanger

Components (optional hydraulic module) :

- A - Shutoff valve
- B - Pump(s)
- C - Check valve
- D - Expansion tank
- E - Relief valve
- F - Air vent
- G - Filling up valve
- H - Drain valve
- I - Manometer
- L - Water tank

Safety / Control devices :

- ⬠ - High pressure switch
- ⬠ - Low pressure switch
- ⬠ - Transducer (optional)
- ⬠ - Water differential pressure switch
- ⊥ - Pressure tapping and refrigerant charging/discharging points

Operating Limits

CLS 182 to 302

CLS			182		202		242		302	
			Min.	Max.	Min.	Max.	Min.	Max.	Min.	Max.
Chiller	Liquid outlet temperature	Water °C	+6 to +15							
		Brine (for low liquid temp. application) °C	-8 to +5							
		Temperature difference K	3 to 7							
	Flow rate l/h	3902	9106	6731	15705	7949	18547	9104	21242	
	Temperature difference bar	10								
Ambient air	Air entering temperature	Cooling - STD / LN / HPF °C	15	46	15	46	15	46	15	46
		Cooling - ELN °C	-18	46	-18	46	-18	46	-18	46
		Cooling - HT °C	15	48	15	48	15	48	15	48
	External static pressure	Standard fans Pa	0							
		High pressure fans - HPF version Pa	80							
Recommended system chilled water volume litres			200		280		330		370	
Nominal supply voltage			400 V / 3 Ph / 50 Hz							

CLS 352 to 602

CLS			352		402		502		552		602	
			Min.	Max.	Min.	Max.	Min.	Max.	Min.	Max.	Min.	Max.
Chiller	Liquid outlet temperature	Water °C	+6 to +15									
		Brine (for low liquid temp. application) °C	-8 to +5									
		Temperature difference K	3 to 7									
	Flow rate l/h	11168	26058	12925	30157	14817	34572	16641	38829	18367	42857	
	Max. operating pressure - Water side bar	10										
Ambient air	Air entering temperature	Cooling - STD / LN / HPF °C	15	46	15	46	15	44	15	44	15	44
		Cooling - ELN °C	-18	46	-18	46	-18	44	-18	44	-18	44
		Cooling - HT °C	15	48	15	48	15	46	15	46	15	46
	External static pressure	Standard fans Pa	0									
		High pressure fans - HPF version Pa	80									
Recommended system chilled water volume litres			450		530		600		677		747	
Nominal supply voltage			400 V / 3 Ph / 50 Hz									

Correction Factors

Fouling factors

EVAPORATOR			CONDENSER		
Fouling factor (m ² .°C/kW)	Cooling capacity factor	Power input factor	Fouling factor (m ² .°C/kW)	Cooling capacity factor	Power input factor
0.044	1.000	1.000	0.044	1.000	1.000
0.088	0.987	0.995	0.088	0.987	1.023
0.176	0.964	0.985	0.176	0.955	1.068
0.352	0.915	0.962	0.352	0.910	1.135

Altitude factors

Altitude (m)	Cooling capacity factor	Power input factor
0	1.000	1.000
600	0.987	1.010
1200	0.973	1.020
1800	0.958	1.029
2400	0.943	1.038

Ethylene glycol solution correction factors

Ethylene glycol percent by weight	%	10	20	30	35	40
Freezing point	°C	-4	-10	-17	-21	-25
Cooling capacity correction factors (1)		0.995	0.985	0.970	0.963	0.955
Power input correction factors (1)		0.998	0.995	0.985	0.983	0.980
Flow rate correction factors		1.015	1.050	1.085	1.123	1.160
Pressure drop correction factors (2)		1.070	1.160	1.235	1.283	1.330

(1) Factors applicable only for glycol solution leaving temperature ≥ 7 °C. For temperatures < 7 °C, refer to table "Low temperature operation correction factors".

(2) Factors applicable only for glycol solution leaving temperature > 5 °C. For temperatures < 5 °C, refer to table "Pressure drop correction factors for low temperature operation".

Low temperature operation correction factors

Leaving water temperature	°C	7	4	2	0	-2	-4	-6	-8
Minimum ethylene glycol percent	%	0	10	10	20	20	30	30	35
Cooling capacity correction factors		1.000	0.887	0.816	0.748	0.685	0.624	0.568	0.513
Power input correction factors		1.000	0.940	0.900	0.865	0.826	0.788	0.753	0.718

Pressure drop correction factors for low temperature operation

Ethylene glycol percent by weight	Glycol solution leaving temperature (°C)	Pressure drop correction factors
10%	5	1.071
	4	1.076
	3	1.081
	2	1.085
20%	1	1.193
	0	1.200
	-1	1.208
	-2	1.215
30%	-3	1.299
	-4	1.306
	-5	1.320
	-6	1.333

Physical Data - CLS STD

CLS STD sizes		182	202	242	302	352	402	502	552	602
Nominal cooling capacity (1)	kW	40.9	54.1	64.9	74.3	90.0	105.3	121.4	135.5	149.5
Compressor power input - Cooling	kW	12.3	18.2	24.2	27.7	33.2	37.5	46.2	51.7	57.1
Maximum power input (2)	kW	18.8	25.4	30.0	35.6	42.5	49.0	59.4	64.7	71.8
EER		3.3	3.0	2.7	2.7	2.7	2.8	2.6	2.6	2.6
Number of refrigerant circuits		2	2	2	2	2	2	2	2	2
Total unit capacity steps	%	50/100	50/100	50/100	50/100	43-57/100	50/100	50/100	43-57/100	50/100
Refrigerant										
Type		HFC 407 C								
Charge	kg	7	7	9	10	12	12	17	18.5	20
Compressors										
Number		2	2	2	2	2	2	2	2	2
Type		Scroll	Scroll	Scroll	Scroll	Scroll	Scroll	Scroll	Scroll	Scroll
Evaporators										
Number		2	2	2	2	2	2	2	2	2
Type		Plate	Plate	Plate	Plate	Plate	Plate	Plate	Plate	Plate
Antifreeze heater power input	W	2 x 35	2 x 35	2 x 35	2 x 35	2 x 35	2 x 35	2 x 35	2 x 35	2 x 35
Air cooled condensers										
Number		2	2	2	2	2	2	2	2	2
Total coil face area per coil	m ²	2.1	2.1	2.1	2.1	2.85	2.85	3.6	3.6	3.6
Number of rows		2	2	3	4	3	4	4	5	5
Fans										
Number		2	2	2	2	3	3	3	3	3
Total air flow	m ³ /h	21000	21000	20300	19700	30000	28700	30000	30000	30000
Power input	kW	0.96	0.96	0.96	0.96	1.44	1.44	1.44	1.44	1.44
Water connection *										
Type		Male gas threaded								
Inlet diameter	inch	2"	2"	2"	2"	2"	2"	2"	2"	2"
Outlet diameter	inch	2"	2"	2"	2"	2"	2"	2"	2"	2"
Dimensions										
Length	mm	2110	2110	2110	2110	2760	2760	3110	3110	3110
Width	mm	1110	1110	1110	1110	1110	1110	1110	1110	1110
Height	mm	1750	1750	1750	1750	1750	1750	1750	1750	1750
Weight										
Basic - Shipping / Operating	kg	600 / 610	630 / 640	754 / 764	808 / 818	888 / 898	962 / 972	1050 / 1060	1185 / 1195	1220 / 1230
1 pump - Shipping / Operating	kg	632 / 642	662 / 672	786 / 796	840 / 850	920 / 930	994 / 1004	1082 / 1092	1217 / 1227	1252 / 1262
2 pumps - Shipping / Operating	kg	652 / 662	682 / 692	806 / 816	860 / 870	940 / 950	1014 / 1024	1102 / 1112	1237 / 1247	1272 / 1282
Water tank + 1 pump - Shipping/Operating	kg	697 / 907	727 / 937	851 / 1061	905 / 1115	1020 / 1350	1094 / 1424	1202 / 1602	1337 / 1737	1372 / 1772
Water tank + 2 pumps - Shipping/Operating	kg	717 / 927	747 / 957	871 / 1081	925 / 1135	1040 / 1370	1114 / 1444	1222 / 1622	1357 / 1757	1392 / 1792
Sound levels										
Sound power levels	dB(A)	84	84	86	86	89	89	90	90	90
Sound pressure levels at 10 meters (3)	dB(A)	52	52	54	54	57	57	58	58	58

(1) Data based on 7 °C leaving chilled water temperature and 35 °C ambient air temperature.

(2) Maximum power input includes : maximum compressor power input and maximum fan power input.

(3) Sound pressure level values refer to ISO standard 3744.

(*) With optional manifolds.

Physical Data - CLS LN

CLS LN sizes		182	202	242	302	352	402	502	552	602
Nominal cooling capacity (1)	kW	40.9	54.1	64.9	74.3	90.0	105.3	121.4	135.5	149.5
Compressor power input - Cooling	kW	12.3	18.2	24.2	27.7	33.2	37.5	46.2	51.7	57.1
Maximum power input (2)	kW	19.3	25.9	30.4	36.0	43.2	49.7	60.1	65.4	72.5
EER		3.3	3.0	2.7	2.7	2.7	2.8	2.6	2.6	2.6
Number of refrigerant circuits		2	2	2	2	2	2	2	2	2
Total unit capacity steps	%	50/100	50/100	50/100	50/100	43-57/100	50/100	50/100	43-57/100	50/100
Refrigerant										
Type		HFC 407C								
Charge	kg	7	7	9	11	12	13	17	18.5	20
Compressors										
Number		2	2	2	2	2	2	2	2	2
Type		Scroll	Scroll	Scroll	Scroll	Scroll	Scroll	Scroll	Scroll	Scroll
Evaporators										
Number		2	2	2	2	2	2	2	2	2
Type		Plate	Plate	Plate	Plate	Plate	Plate	Plate	Plate	Plate
Antifreeze heater power input	W	2 x 35	2 x 35	2 x 35	2 x 35	2 x 35	2 x 35	2 x 35	2 x 35	2 x 35
Air cooled condensers										
Number		2	2	2	2	2	2	2	2	2
Total coil face area per coil	m ²	2.1	2.1	2.1	2.1	2.85	2.85	3.6	3.6	3.6
Number of rows		2	2	3	4	3	4	4	5	5
Fans										
Number		2	2	2	2	3	3	3	3	3
Total air flow	m ³ /h	21000	21000	21000	20100	30500	29000	31500	31500	31500
Power input	kW	1.4	1.4	1.4	1.4	2.1	2.1	2.1	2.1	2.1
Water connection *										
Type		Male gas threaded								
Inlet diameter	inch	2"	2"	2"	2"	2"	2"	2"	2"	2"
Outlet diameter	inch	2"	2"	2"	2"	2"	2"	2"	2"	2"
Dimensions										
Length	mm	2110	2110	2110	2110	2760	2760	3110	3110	3110
Width	mm	1110	1110	1110	1110	1110	1110	1110	1110	1110
Height	mm	1850	1850	1850	1850	1850	1850	1850	1850	1850
Weight										
Basic - Shipping / Operating	kg	600 / 610	630 / 640	754 / 764	808 / 818	888 / 898	962 / 972	1050 / 1060	1185 / 1195	1220 / 1230
1 pump - Shipping / Operating	kg	632 / 642	662 / 672	786 / 796	840 / 850	920 / 930	994 / 1004	1082 / 1092	1217 / 1227	1252 / 1262
2 pumps - Shipping / Operating	kg	652 / 662	682 / 692	806 / 816	860 / 870	940 / 950	1014 / 1024	1102 / 1112	1237 / 1247	1272 / 1282
Water tank + 1 pump - Shipping/Operating	kg	697 / 907	727 / 937	851 / 1061	905 / 1115	1020 / 1350	1094 / 1424	1202 / 1602	1337 / 1737	1372 / 1772
Water tank + 2 pumps - Shipping/Operating	kg	717 / 927	747 / 957	871 / 1081	925 / 1135	1040 / 1370	1114 / 1444	1222 / 1622	1357 / 1757	1392 / 1792
Sound levels										
Sound power levels	dB(A)	80	80	82	82	85	85	86	86	86
Sound pressure levels at 10 meters (3)	dB(A)	48	48	50	50	53	53	54	54	54

(1) Data based on 7 °C leaving chilled water temperature and 35 °C ambient air temperature.

(2) Maximum power input includes : maximum compressor power input and maximum fan power input.

(3) Sound pressure level values refer to ISO standard 3744.

(*) With optional manifolds.

Physical Data - CLS ELN

CLS ELN sizes		182	202	242	302	352	402	502	552	602
Nominal cooling capacity (1)	kW	40.8	54.1	63.8	69.4	88.9	99.1	121.4	135.5	149.5
Compressor power input - Cooling	kW	12.3	18.2	24.7	30.2	33.8	40.8	46.2	51.7	57.1
Maximum power input (2)	kW	19.3	25.9	30.4	36.0	43.2	49.7	60.1	65.4	72.5
EER		3.3	3.0	2.6	2.3	2.6	2.4	2.6	2.6	2.6
Number of refrigerant circuits		2	2	2	2	2	2	2	2	2
Total unit capacity steps	%	50/100	50/100	50/100	50/100	43-57/100	50/100	50/100	43-57/100	50/100
Refrigerant										
Type		HFC 407C								
Charge	kg	7.5	7.5	9	11	12	12	17	18.5	20
Compressors										
Number		2	2	2	2	2	2	2	2	2
Type		Scroll	Scroll	Scroll	Scroll	Scroll	Scroll	Scroll	Scroll	Scroll
Evaporators										
Number		2	2	2	2	2	2	2	2	2
Type		Plate	Plate	Plate	Plate	Plate	Plate	Plate	Plate	Plate
Antifreeze heater power input	W	2 x 35	2 x 35	2 x 35	2 x 35	2 x 35	2 x 35	2 x 35	2 x 35	2 x 35
Air cooled condensers										
Number		2	2	2	2	2	2	2	2	2
Total coil face area per coil	m ²	2.1	2.1	2.1	2.1	2.85	2.85	3.6	3.6	3.6
Number of rows		3	3	4	4	4	4	4	5	5
Fans										
Number		2	2	2	2	3	3	3	3	3
Total air flow	m ³ /h	14400	14400	14400	13800	20100	19900	21650	31500	31500
Power input	kW	1.4	1.4	1.4	1.4	2.1	2.1	2.1	2.1	2.1
Water connection *										
Type		Male gas threaded								
Inlet diameter	inch	2"	2"	2"	2"	2"	2"	2"	2"	2"
Outlet diameter	inch	2"	2"	2"	2"	2"	2"	2"	2"	2"
Dimensions										
Length	mm	2110	2110	2110	2110	2760	2760	3110	3110	3110
Width	mm	1110	1110	1110	1110	1110	1110	1110	1110	1110
Height	mm	1850	1850	1850	1850	1850	1850	1850	1850	1850
Weight										
Basic - Shipping / Operating	kg	642 / 652	668 / 678	796 / 806	818 / 828	950 / 960	974 / 984	1070 / 1080	1205 / 1215	1240 / 1250
1 pump - Shipping / Operating	kg	674 / 684	700 / 710	828 / 838	850 / 860	982 / 992	1006 / 1016	1102 / 1112	1237 / 1247	1272 / 1282
2 pumps - Shipping / Operating	kg	694 / 704	720 / 730	848 / 858	870 / 880	1002 / 1012	1026 / 1036	1122 / 1132	1257 / 1267	1292 / 1302
Water tank + 1 pump - Shipping/Operating	kg	739 / 949	765 / 975	893 / 1103	915 / 1125	1082 / 1412	1106 / 1436	1222 / 1622	1357 / 1757	1392 / 1792
Water tank + 2 pumps - Shipping/Operating	kg	759 / 969	785 / 995	913 / 1123	935 / 1145	1102 / 1432	1126 / 1456	1242 / 1642	1377 / 1777	1412 / 1812
Sound levels										
Sound power levels	dB(A)	77	77	78	78	79	81	82	82	82
Sound pressure levels at 10 meters (3)	dB(A)	45	45	46	46	47	49	50	50	50

(1) Data based on 7 °C leaving chilled water temperature and 35 °C ambient air temperature.

(2) Maximum power input includes : maximum compressor power input and maximum fan power input.

(3) Sound pressure level values refer to ISO standard 3744.

(*) With optional manifolds.

Physical Data - CLS HPF

CLS HPF sizes		182	202	242	302	352	402	502	552	602
Nominal cooling capacity (1)	kW	40.9	54.1	64.9	74.3	90.0	105.3	121.4	133.4	145.4
Compressor power input - Cooling	kW	12.3	18.2	24.2	27.7	33.2	37.5	46.2	51.7	57.1
Maximum power input (2)	kW	19.8	26.4	31.0	36.6	44.0	50.5	60.9	65.4	72.5
EER		3.3	3.0	2.7	2.7	2.7	2.8	2.6	2.6	2.5
Number of refrigerant circuits		2	2	2	2	2	2	2	2	2
Total unit capacity steps	%	50/100	50/100	50/100	50/100	43-57/100	50/100	50/100	43-57/100	50/100
Refrigerant										
Type		HFC 407C								
Charge	kg	7.5	7.5	9	11	12	12	17	18.5	20
Compressors										
Number		2	2	2	2	2	2	2	2	2
Type		Scroll	Scroll	Scroll	Scroll	Scroll	Scroll	Scroll	Scroll	Scroll
Evaporators										
Number		2	2	2	2	2	2	2	2	2
Type		Plate	Plate	Plate	Plate	Plate	Plate	Plate	Plate	Plate
Antifreeze heater power input	W	2 x 35	2 x 35	2 x 35	2 x 35	2 x 35	2 x 35	2 x 35	2 x 35	2 x 35
Air cooled condensers										
Number		2	2	2	2	2	2	2	2	2
Total coil face area per coil	m ²	2.1	2.1	2.1	2.1	2.85	2.85	3.6	3.6	3.6
Number of rows		2	2	3	4	3	4	4	5	5
Fans										
Number		2	2	2	2	3	3	3	3	3
Total air flow	m ³ /h	21000	21000	20300	19700	30000	28700	30000	30000	30000
Power input	kW	1.96	1.96	1.96	1.96	2.94	2.94	2.94	2.94	2.94
Water connection *										
Type		Male gas threaded								
Inlet diameter	inch	2"	2"	2"	2"	2"	2"	2"	2"	2"
Outlet diameter	inch	2"	2"	2"	2"	2"	2"	2"	2"	2"
Dimensions										
Length	mm	2100	2100	2100	2100	2760	2760	3110	3110	3110
Width	mm	1110	1110	1110	1110	1110	1110	1110	1110	1110
Height	mm	1850	1850	1850	1850	1850	1850	1850	1850	1850
Weight										
Basic - Shipping / Operating	kg	600 / 610	630 / 640	754 / 764	808 / 818	888 / 898	962 / 972	1050 / 1060	1185 / 1195	1220 / 1230
1 pump - Shipping / Operating	kg	632 / 642	662 / 672	786 / 796	840 / 850	920 / 930	994 / 1004	1082 / 1092	1217 / 1227	1252 / 1262
2 pumps - Shipping / Operating	kg	652 / 662	682 / 692	806 / 816	860 / 870	940 / 950	1014 / 1024	1102 / 1112	1237 / 1247	1272 / 1282
Water tank + 1 pump - Shipping/Operating	kg	697 / 907	727 / 937	851 / 1061	905 / 1115	1020 / 1350	1094 / 1424	1202 / 1602	1337 / 1737	1372 / 1772
Water tank + 2 pumps - Shipping/Operating	kg	717 / 927	747 / 957	871 / 1081	925 / 1135	1040 / 1370	1114 / 1444	1222 / 1622	1357 / 1757	1392 / 1792
Sound levels										
Sound power levels	dB(A)	87	87	89	89	92	92	93	93	93
Sound pressure levels at 10 meters (3)	dB(A)	55	55	57	57	60	60	61	61	61

(1) Data based on 7 °C leaving chilled water temperature and 35 °C ambient air temperature.

(2) Maximum power input includes : maximum compressor power input and maximum fan power input.

(3) Sound pressure level values refer to ISO standard 3744.

(*) With optional manifolds.

Physical Data - CLS HT

CLS HT sizes		182	202	242	302	352	402	502	552	602
Nominal cooling capacity (1)	kW	43.9	58.3	70.0	79.4	93.4	109.2	125.9	140.4	155.0
Compressor power input - Cooling	kW	12.2	17.7	23.3	25.9	31.8	35.8	44.3	49.5	54.7
Maximum power input (2)	kW	19.8	26.4	31.0	36.6	44.0	50.5	60.9	65.4	72.5
EER		3.6	3.3	3.0	3.1	2.9	3.1	2.8	2.8	2.8
Number of refrigerant circuits		2	2	2	2	2	2	2	2	2
Total unit capacity steps	%	50/100	50/100	50/100	50/100	43-57/100	50/100	50/100	43-57/100	50/100
Refrigerant										
Type		HFC 407C								
Charge	kg	7.5	7.5	9	11	12	12	17	18.5	20
Compressors										
Number		2	2	2	2	2	2	2	2	2
Type		Scroll	Scroll	Scroll	Scroll	Scroll	Scroll	Scroll	Scroll	Scroll
Evaporators										
Number		2	2	2	2	2	2	2	2	2
Type		Plate	Plate	Plate	Plate	Plate	Plate	Plate	Plate	Plate
Antifreeze heater power input	W	2 x 35	2 x 35	2 x 35	2 x 35	2 x 35	2 x 35	2 x 35	2 x 35	2 x 35
Air cooled condensers										
Number		2	2	2	2	2	2	2	2	2
Total coil face area per coil	m ²	2.1	2.1	2.1	2.1	2.85	2.85	3.6	3.6	3.6
Number of rows		2	2	3	4	3	4	4	5	5
Fans										
Number		2	2	2	2	3	3	3	3	3
Total air flow	m ³ /h	36700	36700	35500	25500	38800	37200	39600	30000	30000
Power input	kW	1.96	1.96	1.96	1.96	2.94	2.94	2.94	2.94	2.94
Water connection *										
Type		Male gas threaded								
Inlet diameter	inch	2"	2"	2"	2"	2"	2"	2"	2"	2"
Outlet diameter	inch	2"	2"	2"	2"	2"	2"	2"	2"	2"
Dimensions										
Length	mm	2100	2100	2100	2100	2760	2760	3110	3110	3110
Width	mm	1110	1110	1110	1110	1110	1110	1110	1110	1110
Height	mm	1850	1850	1850	1850	1850	1850	1850	1850	1850
Weight										
Basic - Shipping / Operating	kg	600 / 610	630 / 640	754 / 764	808 / 818	888 / 898	962 / 972	1050 / 1060	1185 / 1195	1220 / 1230
1 pump - Shipping / Operating	kg	632 / 642	662 / 672	786 / 796	840 / 850	920 / 930	994 / 1004	1082 / 1092	1217 / 1227	1252 / 1262
2 pumps - Shipping / Operating	kg	652 / 662	682 / 692	806 / 816	860 / 870	940 / 950	1014 / 1024	1102 / 1112	1237 / 1247	1272 / 1282
Water tank + 1 pump - Shipping/Operating	kg	697 / 907	727 / 937	851 / 1061	905 / 1115	1020 / 1350	1094 / 1424	1202 / 1602	1337 / 1737	1372 / 1772
Water tank + 2 pumps - Shipping/Operating	kg	717 / 927	747 / 957	871 / 1081	925 / 1135	1040 / 1370	1114 / 1444	1222 / 1622	1357 / 1757	1392 / 1792
Sound levels										
Sound power levels	dB(A)	87	87	89	89	92	92	93	93	93
Sound pressure levels at 10 meters (3)	dB(A)	55	55	57	57	60	60	61	61	61

(1) Data based on 7 °C leaving chilled water temperature and 35 °C ambient air temperature.

(2) Maximum power input includes : maximum compressor power input and maximum fan power input.

(3) Sound pressure level values refer to ISO standard 3744.

(*) With optional manifolds.

Electrical Data

Compressors @ 400 V / 3 Ph / 50 Hz

CLS models		Power input at nominal conditions per compressor (kW)	Current at nominal conditions per compressor (A)	Power input at max. conditions per compressor (kW)	Current at max. conditions per compressor FLA (A)	Start up current LRA (A)	Power factor at nominal conditions	Crankcase heater @ 230 V/1Ø (W)	Unit fuse (A)	Cable section (mm ²)
182	Circuit 1	6	10.1	9	15	99	0.84	70	50	16
	Circuit 2	6	10.1	9	15	99	0.84	70		
202	Circuit 1	8.5	14.4	12	21	127	0.84	70	63	25
	Circuit 2	8.5	14.4	12	21	127	0.84	70		
242	Circuit 1	12	20	15	24	150	0.87	65	63	25
	Circuit 2	12	20	15	24	150	0.87	65		
302	Circuit 1	13.7	24.3	17	29	175	0.81	75	80	35
	Circuit 2	13.7	24.3	17	29	175	0.81	75		
352	Circuit 1	13.7	24.3	17	29	175	0.81	75	100	35
	Circuit 2	18.6	31.4	24	38.5	215	0.86	130		
402	Circuit 1	18.6	31.4	24	38.5	215	0.86	130	100	35
	Circuit 2	18.6	31.4	24	38.5	215	0.86	130		
502	Circuit 1	23	38.5	29	47	270	0.86	130	125	50
	Circuit 2	23	38.5	29	47	270	0.86	130		
552	Circuit 1	20.3	34.3	28	48	272	0.84	150	125	70
	Circuit 2	25.3	44.2	35	58.5	320	0.83	150		
602	Circuit 1	25.3	44.2	35	58.5	320	0.83	150	160	70
	Circuit 2	25.3	44.2	35	58.5	320	0.83	150		

Electrical Data (continued)

Units @ 400 V / 3 Ph / 50 Hz

CLS STD models		182	202	242	302	352	402	502	552	602
Nominal current input	A	22.2	30.6	41.9	50.5	58.5	65.6	79.8	81.3	91.2
Maximum current input	A	32.1	43.3	49.9	59.9	70.3	79.8	97.2	108.8	119.8
Nominal power input	kW	13.0	18.0	25.0	28.4	33.7	38.6	47.5	47.0	52.0
Maximum power input	kW	18.8	25.4	30.0	35.6	42.5	49.0	59.4	64.7	71.8
Starting current (LRA)	A	116	150	176	206	247	256	320	370	381

CLS LN / ELN models		182	202	242	302	352	402	502	552	602
Nominal current input	A	22.6	31.0	42.3	50.9	59.2	66.3	80.5	82.0	91.9
Maximum current input	A	32.5	43.7	50.3	60.3	71.0	80.5	97.9	109.5	120.5
Nominal power input	kW	13.4	18.4	25.4	28.8	34.4	39.3	48.1	47.7	52.7
Maximum power input	kW	19.3	25.9	30.4	36.0	43.2	49.7	60.1	65.4	72.5
Starting current (LRA)	A	116	150	176	206	247	257	321	371	382

CLS HPF / HT models		182	202	242	302	352	402	502	552	602
Nominal current input	A	23.7	32.1	43.4	52.0	60.8	67.9	82.1	83.6	93.5
Maximum current input	A	33.6	44.8	51.4	61.4	72.6	82.1	99.5	111.1	122.1
Nominal power input	kW	14.0	19.0	26.0	29.4	35.2	40.1	49.0	48.5	53.5
Maximum power input	kW	19.8	26.4	31.0	36.6	44.0	50.5	60.9	64.7	73.3
Starting current (LRA)	A	118	151	177	207	249	259	322	373	384

CLS STD models with pump		182	202	242	302	352	402	502	552	602
Nominal current input	A	24.3	32.7	45.7	54.3	63.4	70.5	84.7	86.2	96.1
Maximum current input	A	34.2	45.4	53.7	63.7	75.2	84.7	102.1	113.7	124.7
Nominal power input	kW	13.8	18.8	26.5	29.9	35.5	40.4	49.3	48.8	53.8
Maximum power input	kW	19.6	26.2	31.5	37.1	44.3	50.8	61.2	66.5	73.6
Starting current (LRA)	A	118	152	180	210	252	261	325	375	386

CLS LN / ELN with pump		182	202	242	302	352	402	502	552	602
Nominal current input	A	24.7	33.1	46.1	54.7	64.1	71.2	85.4	86.9	96.8
Maximum current input	A	34.6	45.8	54.1	64.1	75.9	85.4	102.8	114.4	125.4
Nominal power input	kW	14.2	19.2	26.9	30.3	36.2	41.1	49.9	49.5	54.5
Maximum power input	kW	20.1	26.7	31.9	37.5	45.0	51.5	61.9	67.2	74.3
Starting current (LRA)	A	119	152	180	210	252	262	326	376	387

CLS HPF / HT with pump		182	202	242	302	352	402	502	552	602
Nominal current input	A	25.8	34.2	47.2	55.8	65.7	72.8	87.0	88.5	98.4
Maximum current input	A	35.7	46.9	55.2	65.2	77.5	87.0	104.4	116.0	127.0
Nominal power input	kW	14.8	19.8	27.5	30.9	37.0	41.9	50.8	50.3	55.3
Maximum power input	kW	20.6	27.2	32.5	38.1	45.8	52.3	62.7	66.5	75.1
Starting current (LRA)	A	120	153	181	211	254	264	327	378	389

Pump(s)

CLS models	Units with 1 pump		Units with 2 pumps	
	kW	A	kW	A
182	0.8	1.7	2 x 0.8	2 x 2.1
202	0.8	1.7	2 x 0.8	2 x 2.1
242	1.1	3.1	2 x 1.5	2 x 3.8
302	1.1	3.1	2 x 1.5	2 x 3.8
352	1.5	3.8	2 x 1.8	2 x 4.9
402	1.8	4.9	2 x 1.8	2 x 4.9
502	1.8	4.9	2 x 1.8	2 x 4.9
552	1.8	4.9	2 x 1.8	2 x 4.9
602	1.8	4.9	2 x 1.8	2 x 4.9

Sound Levels

Sound power levels Lw-dB(A)

CLS STD sizes	Frequency (Hz)							Lw global dB(A)
	125	250	500	1000	2000	4000	8000	
182 STD	84	82	81	80	78	68	57	84
202 STD	84	82	81	80	78	68	57	84
242 STD	86	84	83	82	80	70	59	86
302 STD	86	84	83	82	80	70	59	86
352 STD	89	87	86	85	83	73	62	89
402 STD	89	87	86	85	83	73	62	89
502 STD	90	88	87	86	84	74	63	90
552 STD	90	88	87	86	84	74	63	90
602 STD	90	88	87	86	84	74	63	90

Sound pressure levels Lp-dB(A)

CLS STD sizes	Frequency (Hz)							Lw global dB(A)
	125	250	500	1000	2000	4000	8000	
182 STD	52	50	49	48	46	36	25	52
202 STD	52	50	49	48	46	36	25	52
242 STD	54	52	51	50	48	38	27	54
302 STD	54	52	51	50	48	38	27	54
352 STD	57	55	54	53	51	41	30	57
402 STD	57	55	54	53	51	41	30	57
502 STD	58	56	55	54	52	42	31	58
552 STD	58	56	55	54	52	42	31	58
602 STD	58	56	55	54	52	42	31	58

Note : Sound pressure levels are given at 10 meters according to ISO 3744.

CLS LN sizes	Frequency (Hz)							Lw global dB(A)
	125	250	500	1000	2000	4000	8000	
182 LN	80	78	77	76	74	64	53	80
202 LN	80	78	77	76	74	64	53	80
242 LN	82	80	79	78	76	66	55	82
302 LN	82	80	79	78	76	66	55	82
352 LN	85	83	82	81	79	69	58	85
402 LN	85	83	82	81	79	69	58	85
502 LN	86	84	83	82	80	70	59	86
552 LN	86	84	83	82	80	70	59	86
602 LN	86	84	83	82	80	70	59	86

CLS LN sizes	Frequency (Hz)							Lw global dB(A)
	125	250	500	1000	2000	4000	8000	
182 LN	48	46	45	44	42	32	21	48
202 LN	48	46	45	44	42	32	21	48
242 LN	50	48	47	46	44	34	23	50
302 LN	50	48	47	46	44	34	23	50
352 LN	53	51	50	49	47	37	26	53
402 LN	53	51	50	49	47	37	26	53
502 LN	54	52	51	50	48	38	27	54
552 LN	54	52	51	50	48	38	27	54
602 LN	54	52	51	50	48	38	27	54

Note : Sound pressure levels are given at 10 meters according to ISO 3744.

CLS ELN sizes	Frequency (Hz)							Lw global dB(A)
	125	250	500	1000	2000	4000	8000	
182 ELN	77	75	74	73	71	61	50	77
202 ELN	77	75	74	73	71	61	50	77
242 ELN	78	76	75	74	72	62	51	78
302 ELN	78	76	75	74	72	62	51	78
352 ELN	79	77	76	75	73	63	52	79
402 ELN	81	79	78	77	75	65	54	81
502 ELN	82	80	79	78	76	66	55	82
552 ELN	82	80	79	78	76	66	55	82
602 ELN	82	80	79	78	76	66	55	82

CLS ELN sizes	Frequency (Hz)							Lw global dB(A)
	125	250	500	1000	2000	4000	8000	
182 ELN	45	43	42	41	39	29	18	45
202 ELN	45	43	42	41	39	29	18	45
242 ELN	46	44	43	42	40	30	19	46
302 ELN	46	44	43	42	40	30	19	46
352 ELN	47	45	44	43	41	31	20	47
402 ELN	49	47	46	45	43	33	22	49
502 ELN	50	48	47	46	44	34	23	50
552 ELN	50	48	47	46	44	34	23	50
602 ELN	50	48	47	46	44	34	23	50

Note : Sound pressure levels are given at 10 meters according to ISO 3744.

CLS HPF/HT sizes	Frequency (Hz)							Lw global dB(A)
	125	250	500	1000	2000	4000	8000	
182	87	85	84	83	81	71	60	87
202	87	85	84	83	81	71	60	87
242	89	87	86	85	83	73	62	89
302	89	87	86	85	83	73	62	89
352	92	90	89	88	86	76	65	92
402	92	90	89	88	86	76	65	92
502	93	91	90	89	87	77	66	93
552	93	91	90	89	87	77	66	93
602	93	91	90	89	87	77	66	93

CLS HPF/HT sizes	Frequency (Hz)							Lw global dB(A)
	125	250	500	1000	2000	4000	8000	
182	55	53	52	51	49	39	28	55
202	55	53	52	51	49	39	28	55
242	57	55	54	53	51	41	30	57
302	57	55	54	53	51	41	30	57
352	60	58	57	56	54	44	33	60
402	60	58	57	56	54	44	33	60
502	61	59	58	57	55	45	34	61
552	61	59	58	57	55	45	34	61
602	61	59	58	57	55	45	34	61

Note : Sound pressure levels are given at 10 meters according to ISO 3744.

Cooling Capacities - CLS 182 ÷ 602 STD / LN / HPF

CLS models	LWT (°C)	Ambient air temperature (°C)													
		25		30		32		35		40		43		46	
		Cool. Cap. (kW)	Power Input (kW)	Cool. Cap. (kW)	Power Input (kW)	Cool. Cap. (kW)	Power Input (kW)	Cool. Cap. (kW)	Power Input (kW)	Cool. Cap. (kW)	Power Input (kW)	Cool. Cap. (kW)	Power Input (kW)	Cool. Cap. (kW)	Power Input (kW)
182	6	42.3	10.4	40.9	11.4	40.4	11.7	39.3	12.2	36.2	13.6	34.0	14.3	33.3	14.8
	7	44.0	10.5	42.5	11.5	42.0	11.8	40.9	12.3	37.6	13.7	35.4	14.5	34.7	15.0
	8	44.8	10.6	43.4	11.6	42.8	11.9	41.7	12.5	38.3	13.9	37.7	14.6	36.4	15.2
	10	46.5	10.9	44.9	11.8	44.4	12.2	43.2	12.8	39.8	14.2	39.1	15.0		
	12	48.0	11.2	46.5	12.2	45.9	12.6	44.7	13.1	41.2	14.6	40.5	15.3		
202	6	55.9	15.4	54.1	16.8	53.4	17.2	52.0	18.0	47.8	20.1	44.9	21.2	44.1	22.0
	7	58.2	15.6	56.2	17.0	55.5	17.5	54.1	18.2	49.8	20.3	46.8	21.4	45.9	22.2
	8	59.3	15.8	57.3	17.2	56.6	17.7	55.1	18.4	50.7	20.6	49.8	21.7	48.1	22.5
	10	61.5	16.2	59.4	17.8	58.7	18.1	57.2	18.9	52.6	21.1	51.7	22.1		
	12	63.5	16.6	61.4	18.1	60.7	18.6	59.2	19.4	54.5	21.6	53.6	22.6		
242	6	67.0	20.4	64.8	22.3	64.0	22.9	62.4	23.9	57.3	26.7	53.9	28.2	52.9	29.2
	7	69.8	20.7	67.4	22.6	66.5	23.2	64.9	24.2	59.7	27.0	56.1	28.5	55.0	29.5
	8	71.1	20.9	68.7	22.9	67.9	23.5	66.1	24.5	60.7	27.3	59.7	28.8	57.7	29.9
	10	73.7	21.5	71.3	23.5	70.4	24.1	68.6	25.1	63.1	28.0	62.0	29.4		
	12	76.2	22.1	73.7	24.1	72.7	24.7	70.9	25.8	65.3	28.7	64.2	30.1		
302	6	76.8	23.4	74.2	25.6	73.3	26.2	71.4	27.4	65.6	30.6	61.7	32.2	60.5	33.4
	7	79.9	23.7	77.2	25.9	76.2	26.6	74.3	27.7	68.3	30.9	64.2	32.6	63.0	33.8
	8	81.4	24.0	78.7	26.2	77.7	26.9	75.7	28.1	69.5	31.3	68.4	33.0	66.1	34.2
	10	84.4	24.6	81.6	27.0	80.6	27.6	78.5	28.7	72.2	32.1	71.0	33.7		
	12	87.2	25.3	84.3	27.6	83.2	28.3	81.2	29.5	74.7	32.8	73.5	34.4		
352	6	93.0	28.0	89.9	30.7	88.8	31.4	86.5	32.8	79.5	36.6	74.7	38.6	73.3	40.0
	7	96.8	28.4	93.5	31.0	92.3	31.9	90.0	33.2	82.7	37.1	77.8	39.1	76.3	40.5
	8	98.6	28.7	95.3	31.4	94.1	32.2	91.7	33.6	84.2	37.5	82.8	39.5	80.0	41.0
	10	102.2	29.5	98.8	32.4	97.6	33.0	95.1	34.4	87.5	38.5	86.0	40.4		
	12	105.6	30.3	102.1	33.0	100.8	33.9	98.4	35.4	90.5	39.3	89.1	41.3		
402	6	108.8	31.7	105.2	34.6	103.9	35.5	101.2	37.1	93.0	41.4	87.4	43.6	85.8	45.2
	7	113.3	32.1	109.4	35.0	108.0	36.0	105.3	37.5	96.8	41.9	91.0	44.1	89.3	45.7
	8	115.3	32.5	111.5	35.4	110.1	36.4	107.2	38.0	98.6	42.3	96.9	44.6	93.6	46.3
	10	119.6	33.3	115.6	36.4	114.2	37.3	111.2	38.9	102.3	43.4	100.6	45.6		
	12	123.6	34.2	119.5	37.3	118.0	38.3	115.1	40.0	105.9	44.4	104.2	46.6		
502	6	125.4	39.0	121.3	42.7	119.7	43.8	116.7	45.7	107.3	51.0	100.8	53.8		
	7	130.6	39.5	126.1	43.2	124.5	44.4	121.4	46.2	111.6	51.6	104.9	54.4		
	8	133.0	40.0	128.6	43.6	126.9	44.9	123.6	46.8	113.6	52.2	111.8	55.0		
	10	137.9	41.1	133.3	44.7	131.7	46.0	128.2	47.9	118.0	53.5				
	12	142.5	42.2	137.8	46.0	136.0	47.2	132.7	49.2	122.1	54.7				
552	6	139.9	43.6	135.3	47.7	133.6	48.9	130.2	51.1	119.7	57.0	112.4	60.1		
	7	145.7	44.2	140.7	48.2	138.9	49.6	135.5	51.7	124.5	57.6	117.0	60.8		
	8	148.3	44.7	143.5	48.8	141.6	50.2	137.9	52.3	126.8	58.3	124.7	61.5		
	10	153.9	45.9	148.7	50.1	146.9	51.4	143.1	53.6	131.6	59.8				
	12	159.0	47.2	153.7	51.4	151.8	52.7	148.1	55.1	136.2	61.2				
602	6	166.5	49.1	160.8	53.6	159.1	54.8	155.0	57.1	142.8	63.5				
	7	175.5	52.1	169.7	56.8	167.5	58.3	163.4	60.9	150.4	67.6				
	8	163.7	49.4	158.4	53.9	156.3	55.4	152.3	57.9	139.9	64.5	137.6	67.9		
	10	169.8	50.8	164.2	54.7	162.1	56.8	157.9	59.2	145.3	66.1				
	12	175.5	52.1	169.7	56.8	167.5	58.3	163.4	60.9	150.4	67.6				

Notes : - LWT : Leaving water temperature.
 - Power input values are given for compressors only.

Cooling Capacities - CLS 182 ÷ 602 ELN

CLS models	LWT (°C)	Ambient air temperature (°C)													
		25		30		32		35		40		43		46	
		Cool. Cap. (kW)	Power Input (kW)	Cool. Cap. (kW)	Power Input (kW)	Cool. Cap. (kW)	Power Input (kW)	Cool. Cap. (kW)	Power Input (kW)	Cool. Cap. (kW)	Power Input (kW)	Cool. Cap. (kW)	Power Input (kW)	Cool. Cap. (kW)	Power Input (kW)
182 ELN	6	42.2	10.4	40.8	11.4	40.3	11.7	39.2	12.2	36.1	13.6	33.9	14.4	33.3	14.9
	7	43.9	10.6	42.4	11.5	41.9	11.9	40.8	12.3	37.5	13.8	35.3	14.5	34.6	15.1
	8	44.7	10.7	43.2	11.7	42.7	12.0	41.6	12.5	38.2	13.9	37.6	14.7	36.3	15.2
	10	46.4	11.0	44.8	31.5	44.3	12.3	43.1	12.8	39.7	14.3	39.0	15.0		
	12	47.9	11.3	46.3	12.3	45.7	12.6	44.6	13.2	41.1	14.6	40.4	15.3		
15	50.2	11.7	48.5	12.8	48.0	13.1	46.7	13.6	43.0	15.2	42.4	15.8			
202 ELN	6	55.9	15.4	54.1	16.8	53.4	17.3	52.0	18.0	47.8	20.1	44.9	14.4	44.1	14.9
	7	58.2	15.6	56.2	17.0	55.5	17.5	54.1	18.2	49.8	20.3	46.8	14.5	45.9	15.1
	8	59.3	15.8	57.3	17.2	56.6	17.7	55.1	18.5	50.7	20.6	49.8	14.7	48.1	15.2
	10	61.5	16.2	59.4	46.5	58.7	18.1	57.2	18.9	52.6	21.1	51.7	15.0		
	12	63.5	16.6	61.4	18.1	60.6	18.6	59.2	19.4	54.4	21.6	53.6	15.3		
15	66.5	17.3	64.3	18.9	63.6	19.3	61.9	20.1	57.1	22.4	56.1	15.8			
242 ELN	6	65.9	20.9	63.7	22.8	62.9	23.4	61.3	24.4	56.4	27.2	53.0	28.7	52.0	29.8
	7	68.6	21.1	66.3	23.1	65.4	23.7	63.8	24.7	58.7	27.6	55.1	29.1	54.1	30.1
	8	69.9	21.4	67.6	23.3	66.7	24.0	65.0	25.0	59.7	27.9	58.7	29.4	56.7	30.5
	10	72.5	22.0	70.1	63.0	69.2	24.6	67.4	25.6	62.0	28.6	61.0	30.0		
	12	74.9	22.5	72.4	24.6	71.5	25.2	69.7	26.3	64.2	29.3	63.1	30.7		
15	78.4	23.5	75.8	25.6	74.9	26.2	73.0	27.3	67.3	30.4	66.2	31.7			
302 ELN	6	71.7	25.5	69.3	27.9	68.5	28.6	66.7	29.9	61.3	33.3	57.6	35.1	56.5	36.4
	7	74.7	25.8	72.1	28.2	71.2	29.0	69.4	30.2	63.8	33.7	60.0	35.5	58.8	36.8
	8	76.0	26.1	73.5	28.5	72.6	29.3	70.7	30.6	65.0	34.1	63.9	35.9	61.7	37.3
	10	78.8	26.9	76.2	77.1	75.3	30.0	73.3	31.3	67.4	35.0	66.3	36.7		
	12	81.5	27.6	78.8	30.0	77.8	30.8	75.9	32.2	69.8	35.8	68.7	37.5		
15	85.3	28.7	82.4	31.3	81.5	32.0	79.4	33.4	73.2	37.1	72.0	38.7			
352 ELN	6	91.8	28.5	88.8	31.2	87.7	32.0	85.4	33.4	78.5	37.3	73.8	39.3	72.4	40.8
	7	95.6	28.9	92.4	31.6	91.1	32.5	88.9	33.8	81.7	37.7	76.8	39.8	75.4	41.2
	8	97.4	29.3	94.2	31.9	93.0	32.8	90.5	34.2	83.2	38.2	81.8	40.2	79.1	41.7
	10	101.0	30.1	97.6	86.2	96.4	33.6	93.9	35.0	86.4	39.2	85.0	41.1		
	12	104.3	30.9	100.9	33.6	99.6	34.5	97.2	36.0	89.4	40.0	88.0	42.0		
15	109.3	32.1	105.6	35.0	104.4	35.9	101.8	37.4	93.7	41.6	92.2	43.3			
402 ELN	6	102.4	34.4	99.0	37.7	97.8	38.6	95.3	40.4	87.6	45.0	82.3	47.5	80.7	49.2
	7	106.6	34.9	102.9	38.1	101.6	39.2	99.1	40.8	91.1	45.5	85.6	48.0	84.0	49.8
	8	108.5	35.3	105.0	38.5	103.6	39.6	100.9	41.3	92.7	46.1	91.2	48.6	88.1	50.3
	10	112.6	36.3	108.8	104.1	107.5	40.6	104.7	42.3	96.3	47.3	94.7	49.6		
	12	116.3	37.2	112.5	40.6	111.0	41.7	108.3	43.5	99.7	48.3	98.1	50.7		
15	121.8	38.8	117.7	42.3	116.4	43.3	113.4	45.1	104.5	50.2	102.8	52.3			
502 ELN	6	125.4	39.0	121.3	42.7	119.7	43.8	116.7	45.7	107.3	51.0	95.1	57.9		
	7	130.6	39.5	126.1	43.2	124.5	44.4	121.4	46.2	111.6	51.6	99.0	58.6		
	8	133.0	40.0	128.6	43.6	126.9	44.9	123.6	46.8	113.6	52.2	105.5	59.3		
	10	137.9	41.1	133.3	117.9	131.7	46.0	128.2	47.9	118.0	53.5				
	12	142.5	42.2	137.8	46.0	136.0	47.2	132.7	49.2	122.1	54.7				
15	149.2	43.9	144.1	47.9	142.6	49.0	139.0	51.1	128.0	56.8					
552 ELN	6	139.9	43.6	135.3	47.7	133.6	48.9	130.2	51.1	119.7	57.0	117.7	58.9		
	7	145.7	44.2	140.7	48.2	138.9	49.6	135.5	51.7	124.5	57.6	122.4	59.6		
	8	148.3	44.7	143.5	48.8	141.6	50.2	137.9	52.3	126.8	58.3	124.7	60.3		
	10	153.9	45.9	148.7	131.8	146.9	51.4	143.1	53.6	131.6	59.8				
	12	159.0	47.2	153.7	51.4	151.8	52.7	148.1	55.1	136.2	61.2				
15	166.5	49.1	160.8	53.6	159.1	54.8	155.0	57.1	142.8	63.5					
602 ELN	6	154.4	48.2	149.4	52.7	147.5	54.1	143.7	56.5	132.1	63.0	129.9	65.1		
	7	160.8	48.8	155.3	53.3	153.3	54.8	149.5	57.1	137.5	63.7	135.1	65.9		
	8	163.7	49.4	158.4	53.9	156.3	55.4	152.3	57.9	139.9	64.5	137.6	66.7		
	10	169.8	50.8	164.2	145.7	162.1	56.8	157.9	59.2	145.3	66.1				
	12	175.5	52.1	169.7	56.8	167.5	58.3	163.4	60.9	150.4	67.6				
15	183.8	54.2	177.5	59.2	175.6	60.6	171.1	63.1	157.6	70.2					

Notes : - LWT : Leaving water temperature.
 - Power input values are given for compressors only.

Cooling Capacities - CLS 182 ÷ 602 HT

CLS models	LWT (°C)	Ambient air temperature (°C)															
		25		30		32		35		40		43		46		48	
		Cool. Cap. (kW)	Power Input (kW)	Cool. Cap. (kW)	Power Input (kW)	Cool. Cap. (kW)	Power Input (kW)	Cool. Cap. (kW)	Power Input (kW)	Cool. Cap. (kW)	Power Input (kW)	Cool. Cap. (kW)	Power Input (kW)	Cool. Cap. (kW)	Power Input (kW)	Cool. Cap. (kW)	Power Input (kW)
182 HT	6	45.4	10.3	43.9	11.2	43.3	11.5	42.2	12.0	38.8	13.4	36.5	14.2	35.8	14.7	34.8	15.1
	7	47.3	10.4	45.6	11.4	45.0	11.7	43.9	12.2	40.4	13.6	38.0	14.3	37.2	14.8	36.2	15.3
	8	48.1	10.5	46.5	11.5	45.9	11.8	44.7	12.3	41.1	13.7	40.4	14.5	39.1	15.0		
	10	49.9	10.8	48.2	12.1	47.7	12.1	46.4	12.6	42.7	14.1	42.0	14.8	40.6	14.2		
	12	51.6	11.1	49.9	12.1	49.2	12.4	48.0	13.0	44.2	14.4	43.5	15.1				
	15	54.0	11.6	52.2	12.6	51.6	12.9	50.3	13.5	46.3	15.0	45.6	15.6				
202 HT	6	60.3	14.9	58.3	16.3	57.5	16.7	56.1	17.5	51.5	19.5	48.4	20.5	47.5	21.3	46.2	21.9
	7	62.7	15.1	60.6	16.5	59.8	17.0	58.3	17.7	53.6	19.7	50.4	20.8	49.4	21.5	48.0	22.2
	8	63.9	15.3	61.8	16.7	61.0	17.1	59.4	17.9	54.6	19.9	53.7	21.0	51.9	21.8		
	10	66.3	15.7	64.0	17.6	63.3	17.6	61.6	18.3	56.7	20.4	55.7	21.5	53.9	20.6		
	12	68.5	16.1	66.2	17.6	65.3	18.0	63.8	18.8	58.7	20.9	57.7	21.9				
	15	71.7	16.8	69.3	18.3	68.5	18.7	66.8	19.5	61.5	21.7	60.5	22.6				
242 HT	6	72.2	19.6	69.8	21.4	69.0	22.0	67.3	23.0	61.8	25.7	58.1	27.1	57.0	28.1	55.4	28.9
	7	75.2	19.9	72.7	21.7	71.7	22.3	70.0	23.3	64.4	25.9	60.5	27.4	59.3	28.3	57.7	29.2
	8	76.6	20.1	74.1	22.0	73.2	22.6	71.2	23.5	65.4	26.2	64.4	27.7	62.2	28.7		
	10	79.4	20.7	76.9	23.2	75.9	23.2	73.9	24.1	68.0	26.9	66.8	28.3	64.6	27.2		
	12	82.1	21.2	79.4	23.2	78.4	23.7	76.4	24.8	70.4	27.6	69.2	28.9				
	15	86.0	22.1	83.1	24.1	82.1	24.7	80.1	25.8	73.7	28.6	72.5	29.8				
302 HT	6	82.1	21.9	79.3	24.0	78.3	24.5	76.3	25.7	70.1	28.7	65.9	30.2	64.7	31.3	62.9	32.3
	7	85.4	22.2	82.5	24.3	81.4	24.9	79.4	25.9	73.0	28.9	68.6	30.5	67.3	31.7	65.4	32.5
	8	87.0	22.5	84.1	24.5	83.1	25.2	80.9	26.3	74.3	29.3	73.1	30.9	70.7	32.0		
	10	90.2	23.0	87.2	26.2	86.2	25.9	83.9	26.9	77.2	30.1	75.9	31.6	73.3	30.3		
	12	93.2	23.7	90.1	25.9	88.9	26.5	86.8	27.6	79.8	30.7	78.6	32.2				
	15	97.6	24.6	94.3	26.9	93.3	27.5	90.9	28.7	83.7	31.9	82.4	33.3				
352 HT	6	96.5	26.8	93.2	29.4	92.1	30.1	89.7	31.4	82.5	35.1	77.5	37.0	76.0	38.3	73.9	39.5
	7	100.4	27.2	97.0	29.7	95.7	30.6	93.4	31.8	85.8	35.5	80.7	37.4	79.1	38.8	76.9	39.9
	8	102.3	27.5	98.8	30.1	97.6	30.8	95.1	32.2	87.3	35.9	85.9	37.8	83.0	39.3		
	10	106.0	28.3	102.5	31.6	101.2	31.6	98.6	32.9	90.8	36.9	89.2	38.7	86.2	37.2		
	12	109.5	29.0	105.9	31.6	104.6	32.5	102.1	33.9	93.9	37.6	92.4	39.6				
	15	114.7	30.2	110.9	32.9	109.6	33.7	106.8	35.1	98.4	39.1	96.9	40.8				
402 HT	6	112.8	30.3	109.1	33.0	107.7	33.9	104.9	35.4	96.4	39.5	90.6	41.6	89.0	43.2	86.5	44.4
	7	117.5	30.7	113.4	33.4	112.0	34.4	109.2	35.8	100.4	40.0	94.4	42.1	92.6	43.7	90.0	44.9
	8	119.6	31.0	115.6	33.8	114.2	34.8	111.2	36.3	102.2	40.4	100.5	42.6	97.1	44.2		
	10	124.0	31.8	119.9	35.6	118.4	35.6	115.3	37.2	106.1	41.5	104.3	43.6	100.8	41.8		
	12	128.2	32.7	123.9	35.6	122.4	36.6	119.3	38.2	109.8	42.4	108.0	44.5				
	15	134.2	34.0	129.6	37.2	128.3	38.0	124.9	39.6	115.1	44.0	113.2	45.9				
502 HT	6	130.0	37.4	125.8	40.9	124.1	42.0	121.0	43.8	111.2	48.9	104.5	51.5	102.5	53.4		
	7	135.4	37.8	130.7	41.4	129.1	42.5	125.9	44.3	115.7	49.4	108.8	52.1	106.7	53.9		
	8	137.9	38.3	133.3	41.8	131.6	43.0	128.1	44.8	117.8	50.0	115.9	52.7	112.0	54.6		
	10	143.0	39.4	138.2	44.1	136.5	44.1	132.9	45.9	122.3	51.2	120.3	53.8				
	12	147.7	40.4	142.9	44.1	141.0	45.2	137.6	47.1	126.6	52.4	124.5	55.0				
	15	154.7	42.1	149.4	45.9	147.8	46.9	144.1	48.9	132.7	54.4	130.5	56.7				
552 HT	6	145.1	41.8	140.3	45.7	138.5	46.9	135.0	49.0	124.1	54.6	116.6	57.6	114.4	59.7		
	7	151.1	42.3	145.9	46.2	144.0	47.5	140.4	49.5	129.1	55.2	121.3	58.2	119.0	60.3		
	8	153.8	42.8	148.7	46.7	146.8	48.0	143.0	50.1	131.4	55.9	129.3	58.9	124.9	61.0		
	10	159.5	44.0	154.2	49.2	152.3	49.2	148.3	51.3	136.5	57.3	134.2	60.2				
	12	164.8	45.2	159.4	49.2	157.3	50.5	153.5	52.7	141.2	58.6	139.0	61.5				
	15	172.6	47.0	166.7	51.3	165.0	52.5	160.7	54.7	148.1	60.8	145.7	63.4				
602 HT	6	160.1	46.2	154.8	50.5	152.9	51.8	149.0	54.1	136.9	60.3	128.7	63.6	126.3	66.0		
	7	166.7	46.8	161.0	51.1	158.9	52.5	155.0	54.7	142.5	61.0	133.9	64.4	131.4	66.7		
	8	169.7	47.3	164.2	51.7	162.1	53.1	157.9	55.4	145.1	61.8	142.7	65.1	137.8	67.5		
	10	176.1	48.6	170.2	53.6	168.1	54.4	163.7	56.7	150.6	63.4	148.1	66.5				
	12	181.9	49.9	175.9	54.4	173.7	55.9	169.4	58.3	155.9	64.8	153.4	68.0				
	15	190.5	52.0	184.0	56.7	182.1	58.0	177.4	60.5	163.4	67.3	160.8	70.1				

Notes : - LWT : Leaving water temperature.
 - Power input values are given for compressors only.

Water Pressure Drop Curves

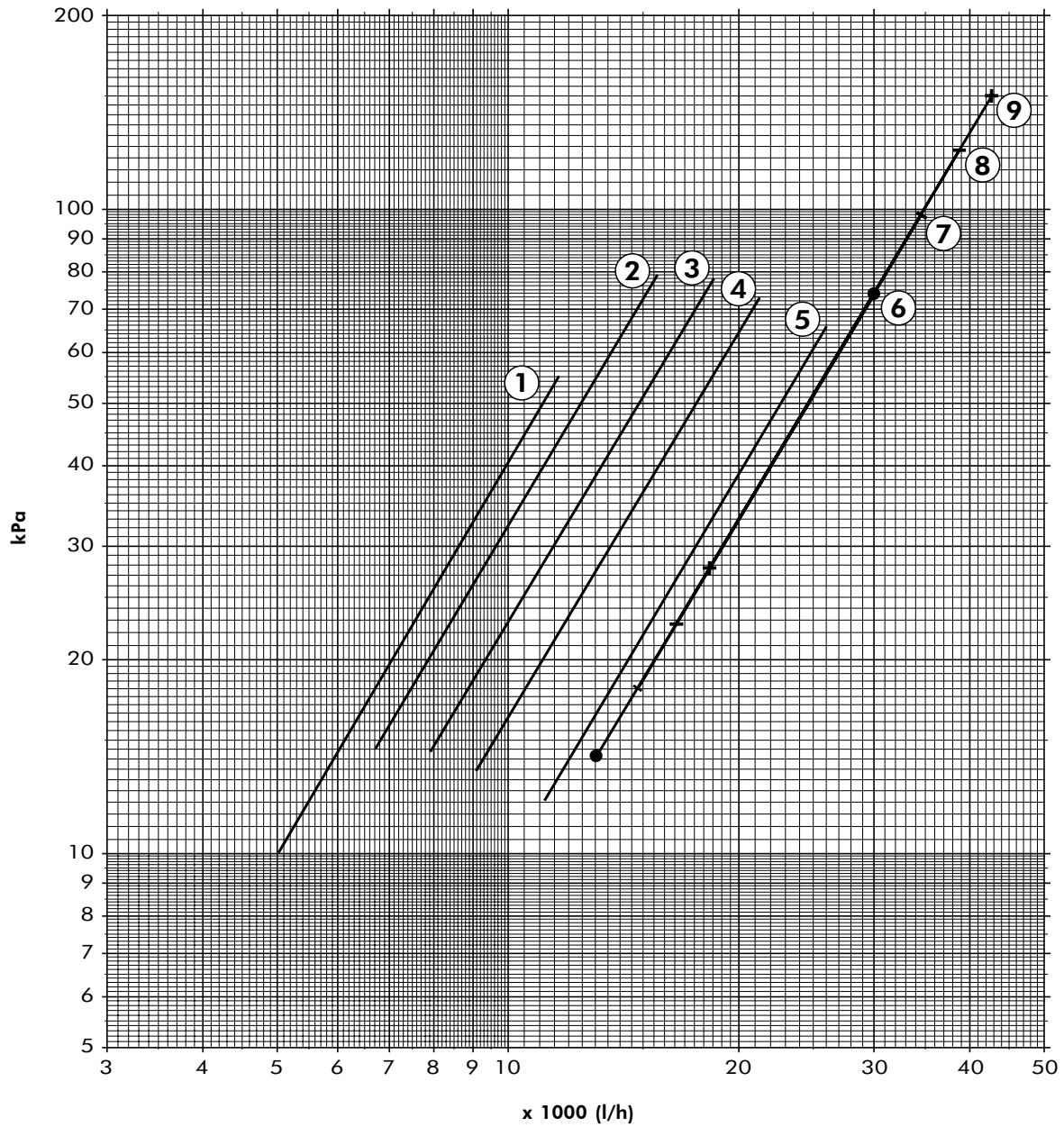

- ① Size 182
- ② Size 202
- ③ Size 242
- ④ Size 302
- ⑤ Size 352
- ⑥ Size 402
- ⑦ Size 502
- ⑧ Size 552
- ⑨ Size 602

Integrated Hydraulic Module Data (optional)

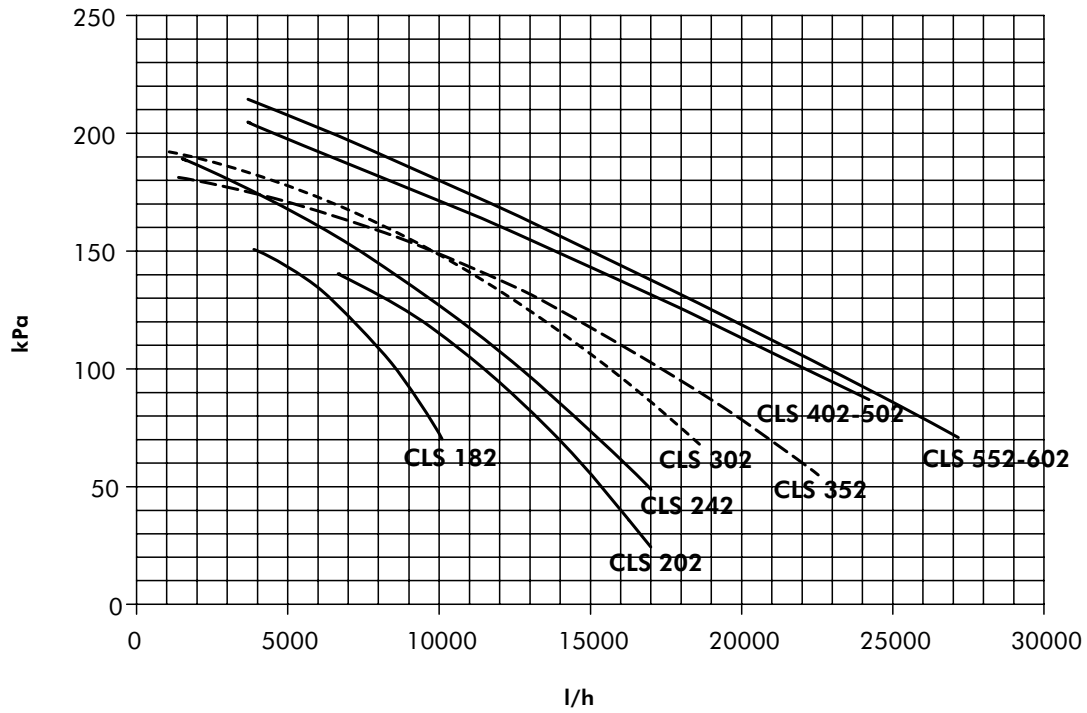

CLS sizes		182	202	242	302	352	402	502	552	602
Water tank volume (all versions)	litres	210	210	210	210	330	330	400	400	400
Expansion tank volume (all versions)	litres	12	12	12	12	18	18	18	18	18
Antifreeze electric heater	kW	0.2	0.2	0.2	0.2	0.4	0.4	0.4	0.4	0.4

Dimensions

Models CLS 182 to 302 STD/LN/ELN/HPF/HT

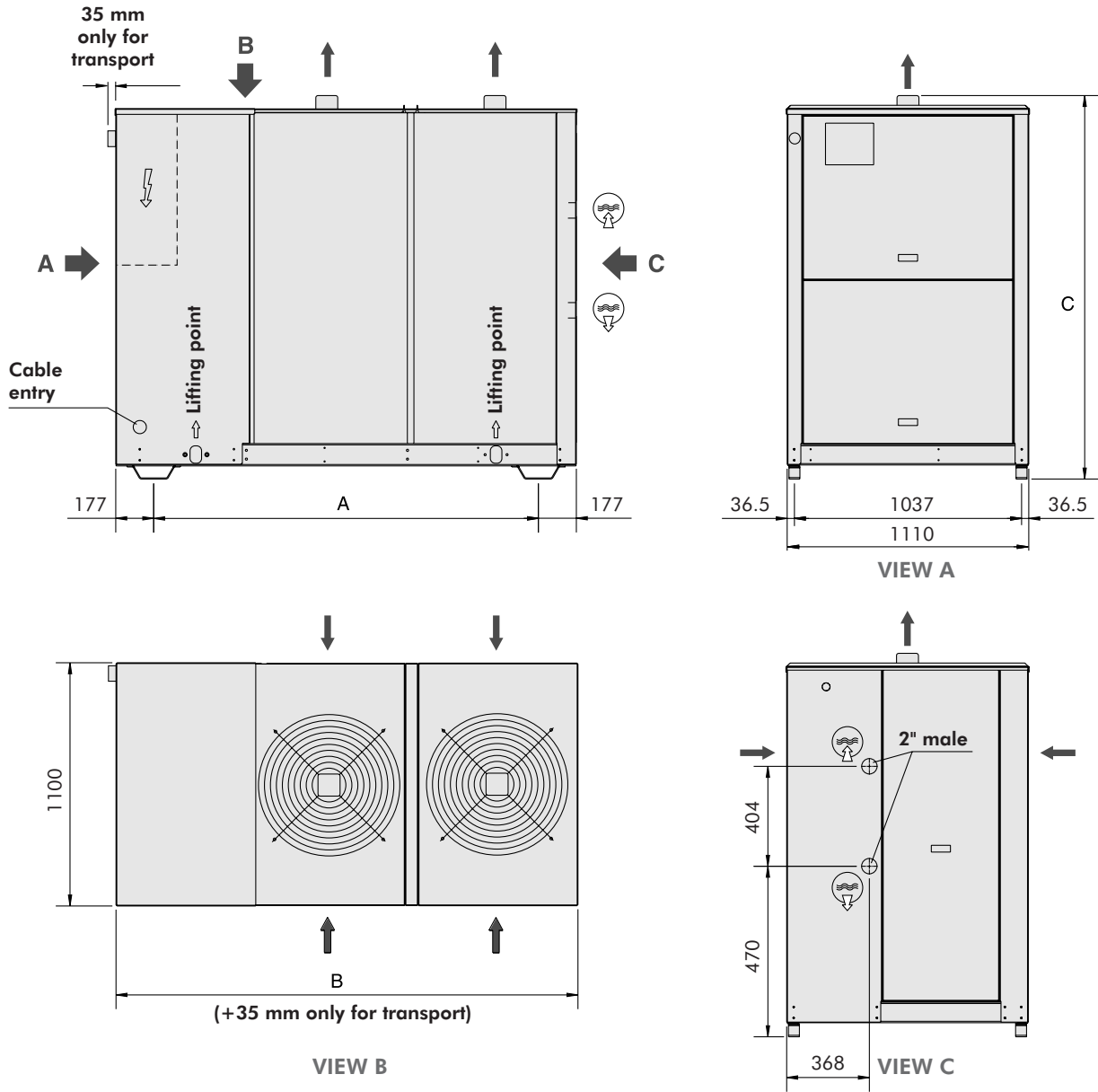

Models	Versions	Dimensions A (mm)	Dimensions B (mm)	Dimensions C (mm)	Number of fans
CLS 182	Standard	1756	2110	1750	2
	LN/HPF/HT	1756	2110	1850	2
	ELN	1756	2110	1850	2
CLS 202	Standard	1756	2110	1750	2
	LN/HPF/HT	1756	2110	1850	2
	ELN	1756	2110	1850	2
CLS 242	Standard	1756	2110	1750	2
	LN/HPF/HT	1756	2110	1850	2
	ELN	1756	2110	1850	2
CLS 302	Standard	1756	2110	1750	2
	LN/HPF/HT	1756	2110	1850	2
	ELN	1756	2110	1850	2

Note : For units without hydraulic module, the water connections are done on the optional 2" male threaded gas type manifolds located inside the unit.

Dimensions (continued)

Models CLS 352 to 602 STD/LN/ELN/HPF/HT

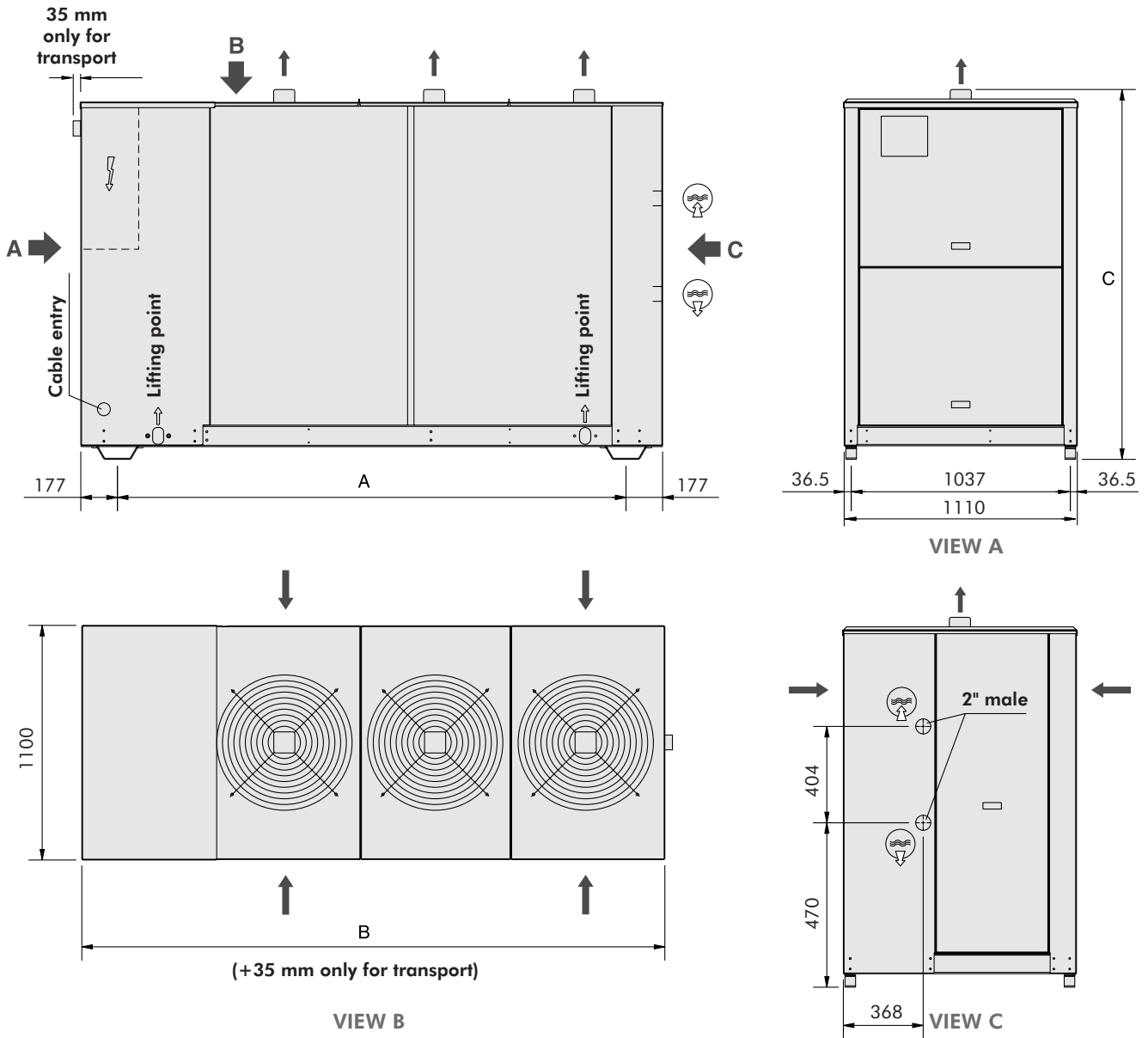

Models	Versions	Dimensions A (mm)	Dimensions B (mm)	Dimensions C (mm)	Number of fans
CLS 352 & 402	Standard	2406	2760	1750	3
	LN/HPF/HT	2406	2760	1850	3
	ELN	2406	2760	1850	3
CLS 502 to 602	Standard	2756	3110	1750	3
	LN/HPF/HT	2756	3110	1850	3
	ELN	2756	3110	1850	3

Note : For units without hydraulic module, the water connections are done on the optional 2" male threaded gas type manifolds located inside the unit.

Space Requirements

Single unit applications

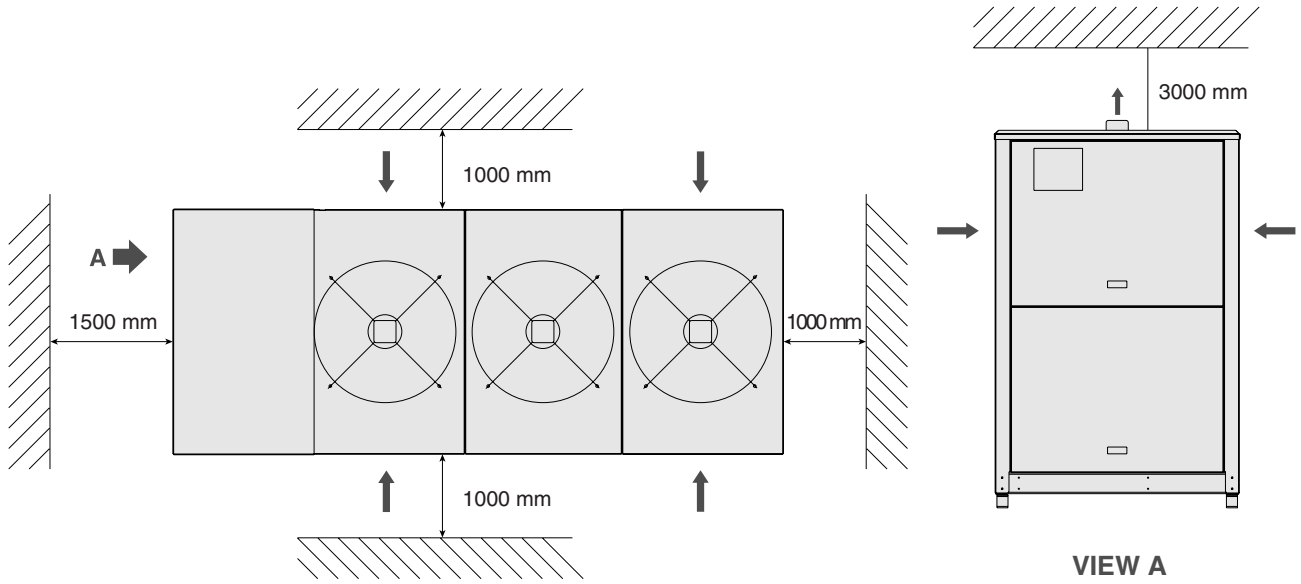

Multi units applications

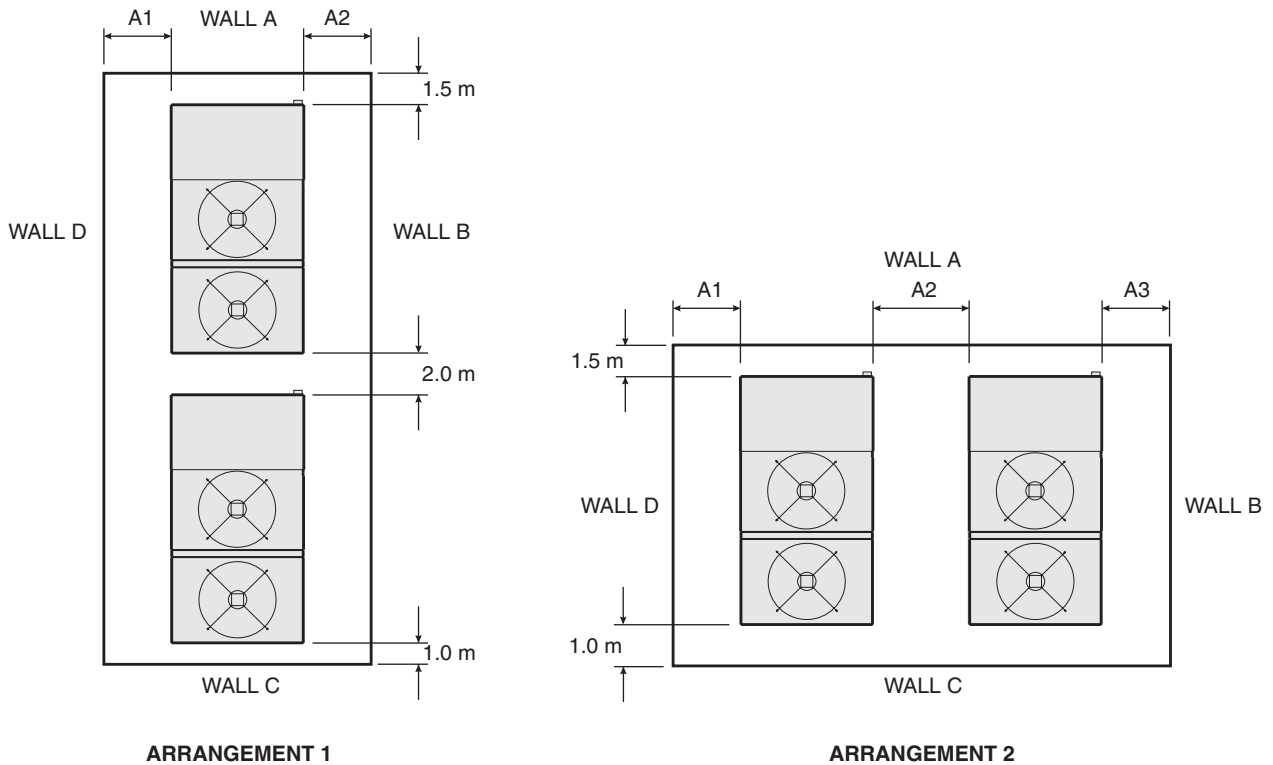

	LOUVRED A & C SOLID B & D			SOLID A & B SOLID C & D			SOLID A & C LOUVRED B & D			LOUVRED A & B SOLID C & D			LOUVRED A & D SOLID B & C		
	A1	A2	A3	A1	A2	A3	A1	A2	A3	A1	A2	A3	A1	A2	A3
ARRANGEMENT 1	1.0	1.0		1.0	1.0		0.8	0.8		1.0	0.8		0.8	1.0	
ARRANGEMENT 2	1.0	1.5	1.0	1.0	2.0	1.0	0.8	2.0	0.8	1.0	1.5	0.8	0.8	1.5	1.0

Note : No more than one wall can be higher than the unit.
The area enclosed by the wall must be kept clear of all obstructions that would impede air flow to the unit.

Wesper[®]

As part of our ongoing product improvement programme, our products are subject to change without prior notice. Non contractual photos.

Wesper

42 cours Jean-Jaurès
17800 Pons
FRANCE

☎ : +33-5 46 92 33 33

☎ : +33-5 46 91 38 33 / 5 46 91 26 44 (Export Department)

www.wesper.com

